

BATCO



Belt Conveyors & Accessories

Batco Belt Conveyors and equipment are built tough to perform, yet designed and engineered for gentle handling of delicate crops, seeds and commodities.

Gentle Handling

Specialty crops, seed and some commodities are very susceptible to impact damage caused by conventional grain handling systems. A Batco Belt Conveyor minimizes impact damage and helps protect grade quality and germination performance of seed. Not recommended on oil seeds.

Low Maintenance/Long Wear

Engineered, designed and built for rugged, long-lasting performance with heavy duty features like our quality rubber belting, rated at 3,000 hours.

High Capacity

All Batco Conveyors are designed and built for high capacity and performance at a maximum height of 30°. Capacity increases as the angle of elevation decreases. See specifications for model performance.

Low Horsepower

Batco's unique design requires half the horsepower of screw augers, saving energy and freeing up larger tractors for other purposes.

Clean Convenience

Batco's unique design requires half the horsepower of screw augers, saving energy and freeing up larger tractors for other purposes.



PINCH S-DRIVE

Batco's unique Pinch S-Drive is available on all series (not transfers or pit stops) and eliminates slippage by making it easy to set and maintain belt traction. The spring take up helps to maintain tension while less friction minimizes damage to the conveyor belt, also invoking minimal stress on the bearings. Gas or electric Pinch S-Drive options available.

PINCH TOP DRIVE

An affordable option unique to Batco, is the Pinch Top Drive. The pinch roller system at the top end ensures positive belt traction. Electric or hydraulic Pinch Top Drive options are available.

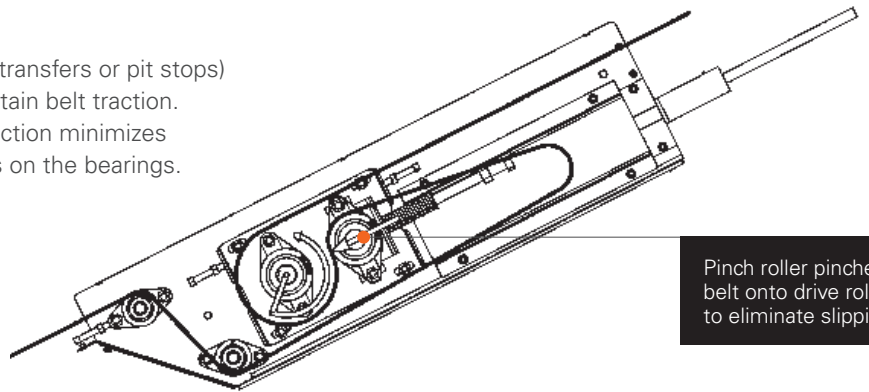

Pinch roller pinches belt onto drive roller to eliminate slipping

BATCO

MANUFACTURING

Batco started in 1992 and later became the founding company of AGI. Humble beginnings had Batco building two-wheel carts; fast forward to present day where Batco manufactures an extensive line of portable and stationary belt conveyors used in storage and handling facilities for grain and fertilizer. Over the past two decades, Batco has grown their sales through innovative products and a strong focus on customer needs and services.

Outgrowing their 33,000 square foot facility, in 2013, Batco moved into an 114,000 square foot facility featuring lean manufacturing processes, robotic welding and a state-of-the-art powder coat paint system which will increase quality, productivity and has the potential to double capacity.

The improved facility provides more space to accommodate robotic welding, delivering more consistent and reliable production, as well as lean manufacturing, which ensures efficient and quick production to meet customer demand.

Powder coating is an advanced method of applying a protective finish. The powder used for this process is a mixture of finely ground particles of pigment and resin, which is sprayed onto the surface of our products. The result is a much thicker coating with a classic vibrant Batco orange finish that is more durable and long lasting than conventional liquid paint.



BELT CONVEYORS

1300 | 1500 | 2000 | 2400

- Weather guards are standard on all conveyors
- Maximum service height at 30-degrees
- All belts are made of 2-ply Chevron, with nylon slider back
- Plastic hood and collapsible canvas hoppers provides excellent cushioning for fragile materials



Optional Self-Propelled Kit

1300 SERIES 1500 SERIES

10" Tube | 13" Belt

- Capacity rated up to 3,500 bu/hr
- Available in lengths from 30' to 55'
- 10" diameter, 14-gauge tube

FEATURES

- A-frame undercarriage
- Cable trussing on the 55' Model
- Optional self-propelled kit available

DRIVE OPTIONS

- Pinch S-Drive (55' only)
 - Gas
 - Electric
 - PTO
- Top Drive (30' - 45')
 - Hydraulic
 - Electric

10" Tube | 15" Belt

- Capacity rated up to 6,000 bu/hr
- Available in lengths from 30' to 100'
- 10" diameter, 14-gauge tube
 - 12-gauge tube for the first 30' on the 55'-100' models

FEATURES

- A-frame undercarriage on 30' - 55' lengths
- Hydraulic scissor lift on 65' - 100'
 - Offers greater reach and bin clearance
- Cable trussing on the 55' - 100' models
- Extendable axles on 85' - 100' models
- Optional self-propelled kit available

DRIVE OPTIONS

- Pinch S-Drive (55'-100')
 - Gas
 - Electric
 - PTO (side or front)
- Top Drive (30' & 35')
 - Hydraulic
 - Electric
- Pinch Top Drive (40' & 45')
 - Hydraulic
 - Electric





**1500
SERIES**

2000 SERIES

2400 SERIES

14" Tube | 20" Belt

- Capacity rated up to 9,000 bu/hr
- Available in lengths from 35' to 120'
- 14" diameter, 12-gauge tube

14" Tube | 23.5" Belt

- Capacity rated up to 14,000 bu/hr
- Available in lengths from 65' to 120'
- 14" diameter, 12-gauge tube

FEATURES 2000 | 2400

- A-frame undercarriage on 35' – 55' lengths
- Dual cylinder hydraulic scissor lift on 65' – 95' lengths
- Triple cylinder hydraulic scissor lift on the 105' – 120' models
- Cable trussing on 55' – 110', steel trussing on the 120'
- Heavy-duty, 1 15/16" shafts and industrial bearings

DRIVE OPTIONS 2000 | 2400

- Pinch S-Drive
 - Electric
 - PTO (side or front)
- Top Drive (35' only)
 - Electric



**2400
SERIES**



**FIELD
LOADER**



FIELD LOADERS

1300 | 1500 | 1800 | 2400

Batco Field Loaders include all the benefits of the standard hopper Belt Conveyors but feature an extended low-profile hopper, with unique collapsible design.

- Optional self-propelled kit available on all models

1300 SERIES | 1500 SERIES | 1800 SERIES | 2400 SERIES

10" Tube | 13" Belt

- Capacity up to 4,500 bu/hr
- 35' or 45' lengths available

10" Tube | 15" Belt

- Capacity up to 6,000 bu/hr
- 35' or 45' lengths available

14" Tube | 18" Belt

- Capacity up to 8,000 bu/hr
- 35' length available

14" Tube | 23.5" Belt

- Capacity up to 14,000 bu/hr
- 35' length available

DRIVE OPTIONS 1300 | 1500 | 1800 | 2400

- Pinch S-Drive
 - Gas
 - Electric

- Pinch Top Drive
 - Electric
 - Hydraulic (1300, 1500 & 1800)

ALSO AVAILABLE

2435 Railcar Unloader with lower profile hopper to suit above-track loading

- Available with gas or electric Pinch S-Drive
- Capacity up to 14,000 bu/hr
- Ultra low hopper = 4" hopper height

SWING AWAY

1500 | 2000 | 2400

A low-profile transfer conveyor/swing away with collapsible hopper is available on the 1500, 2000 and 2400 series conveyors for the 65' – 120' models.

- Center mounted CV PTO shaft with gearbox drive system
- Standard with hydraulic winch
- Hydraulic drive swing
 - Requires approximately 12 GPM on 1500 series, 18 GPM on 2000 and 2400 series

LOW PROFILE TRANSFERS

1300 | 1500 | 1800

- 7 ½" hopper clearance; 9" clearance at transition
- Discharge height – 28"
- 30" x 56" collapsible hopper on 1314 LP & 1814 LP
- 30" x 75" collapsible hopper on 1515 LP
- Hydraulic, electric or gas drive options



LOW PROFILE
TRANSFERS

PITSTOP

1800 | 2400

- Quick, convenient unloading
- Gentle handling and fast setup
- Low, 7 ½" clearance
- 8' x 12' easy access dump platform
- Large, 32" x 114" hopper
- Hydraulic lift on transport wheels
- Discharge height – 28"
- Overall length – 25' on 1800 series
– 27' on 2400 series
- Hydraulic, gas or electric drive options
- Optional self-propelled kit available



PIT
STOP

